

### Features

- APD with 0.2 mm<sup>2</sup> active area
- Slow multiplication curve
- QE > 80% @ 750 nm-910 nm
- Fast rise time, low noise
- Optimum gain: 50-60

### Description

Circular active area APD chip with NIR enhanced sensitivity. Ceramic carrier type non hermetic SMD package with clear glass or filter window. Reflow solderable.

### Application

- Laser range finder
- High speed photometry
- High speed optical communications
- Medical equipment

### RoHS

2002/95/EC



### Absolute maximum ratings

Symbol	Parameter	Min	Max	Unit
T <sub>STG</sub>	Storage temp	-40	100	°C
T <sub>OP</sub>	Operating temp	-20	70	°C
M <sub>max</sub>	Gain (I <sub>PO</sub> = 1 nA)	200		
I <sub>PEAK</sub>	Peak DC current		0.25	mA

### Spectral response (M = 100)

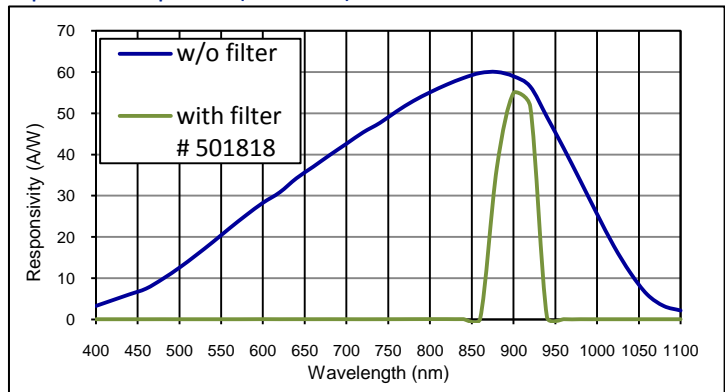

### Schematic

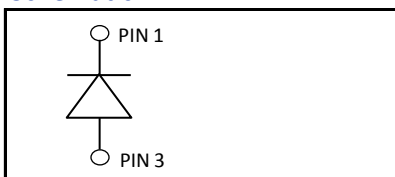

### Electro-optical characteristics @ 23 °C

Symbol	Characteristic	Test Condition	Min	Typ	Max	Unit
	Active area		diameter 500			µm
	Active area		0.196			mm <sup>2</sup>
I <sub>D</sub>	Dark current	M = 100		0.8	5.0	nA
C	Capacitance	M = 100		1.2		pF
	Responsivity	M = 100; λ = 905 nm	52	58	60	A/W
	Responsivity with filter	Article <b>501818</b> ; M = 100; λ = 905 nm	42	55		A/W
t <sub>R</sub>	Rise time	M = 100; λ = 905 nm; R <sub>L</sub> = 50 Ω		0.55		ns
	Cut-off frequency	-3dB		0.5		GHz
V <sub>BR</sub>	Breakdown voltage	I <sub>R</sub> = 2 µA, V <sub>BR</sub> - binning available	160		240	V
	Temperature coefficient	Change of V <sub>BR</sub> with temperature	1.25		1.55	V/K
	Excess noise factor	M = 100		2.5		
	Excess noise index	M = 100		0.2		

#### European, International Sales:



First Sensor AG  
 Peter-Behrens-Strasse 15  
 12459 Berlin  
 Germany  
 T +49 30 6399 2399  
 F +49 30 639923-752  
 sales.opto@first-sensor.com

#### USA:

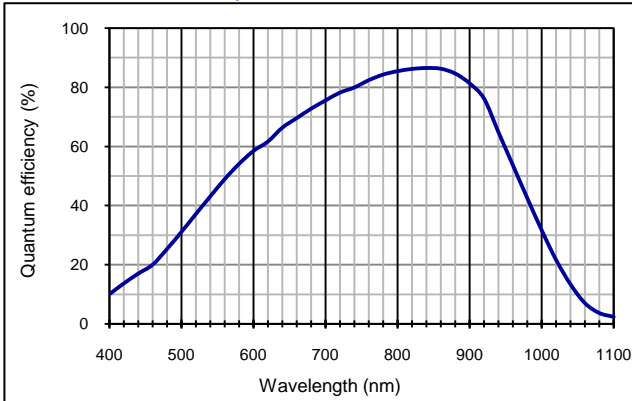
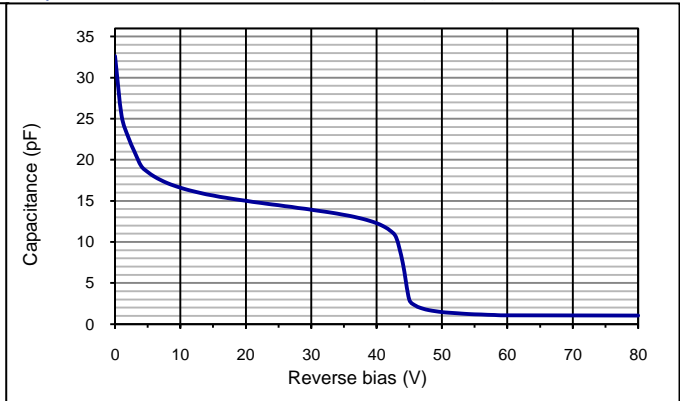
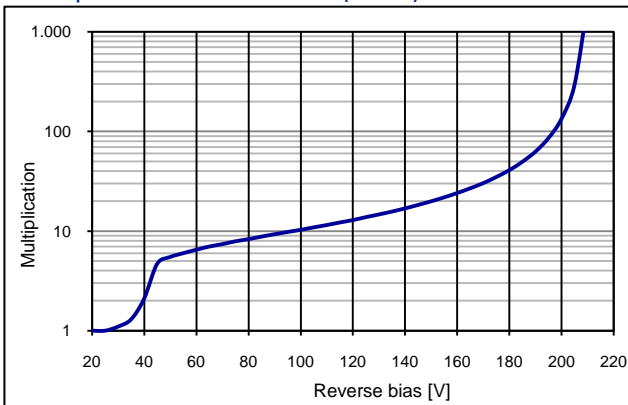
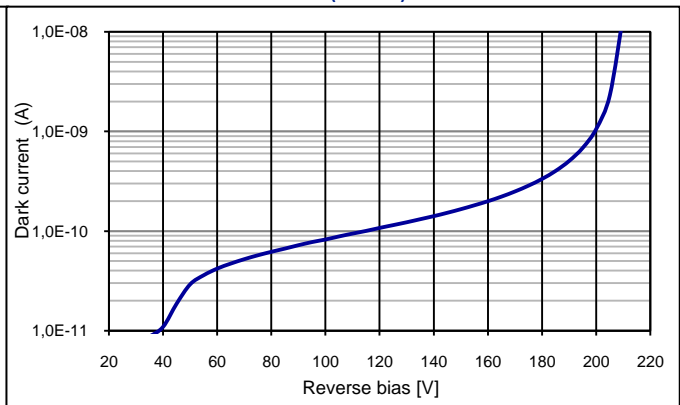
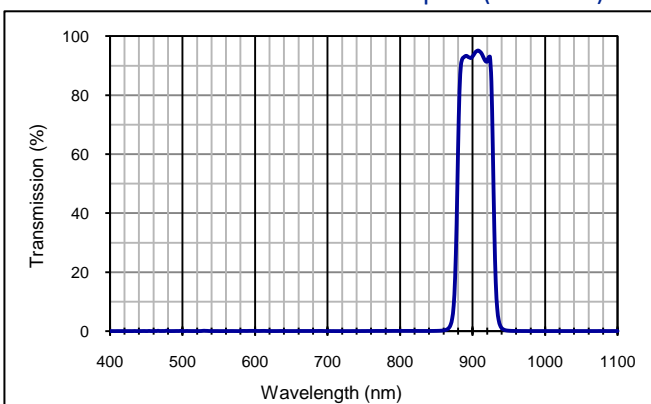

First Sensor Inc.  
 5700 Corsa Avenue #105  
 Westlake Village  
 CA 91362 USA  
 T +1 818 706 3400  
 F +1 818 889 7053  
 sales.us@first-sensor.com

**Quantum efficiency (23 °C)**

**Capacitance as fct of reverse bias (23 °C)**

**Multiplication as fct of bias (23 °C)**

**Dark current as fct of bias (23 °C)**

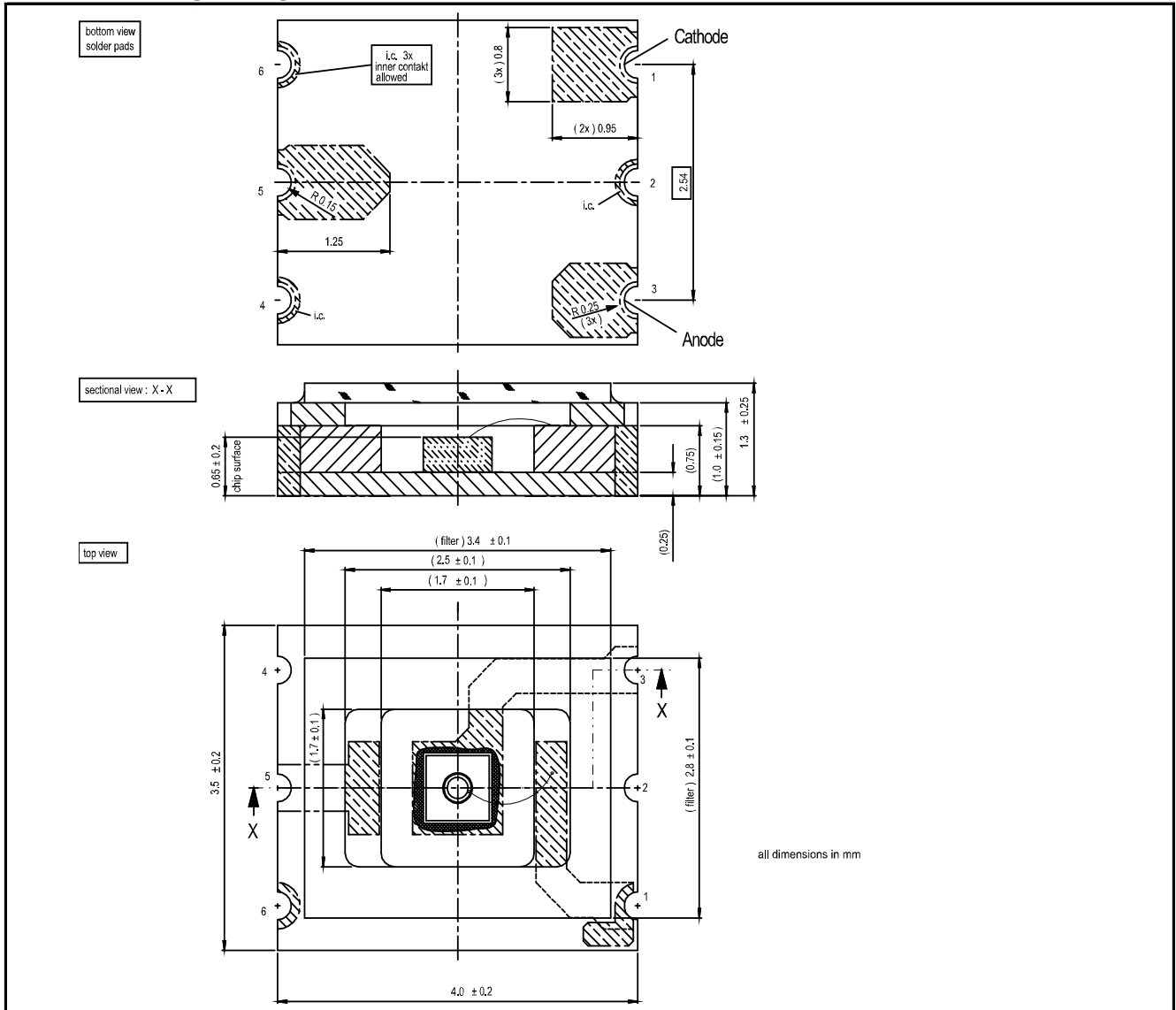
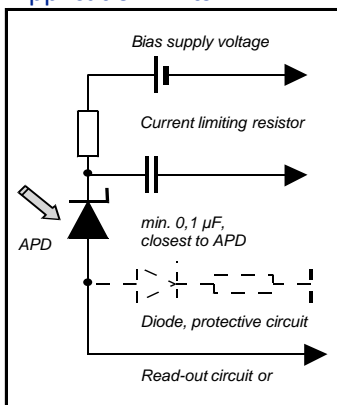
**Filter characteristics 905 nm band pass (#501818)**

**European, International Sales:**

First Sensor AG  
 Peter-Behrens-Strasse 15  
 12459 Berlin  
 Germany  
 T +49 30 6399 2399  
 F +49 30 639923-752  
 sales.opto@first-sensor.com

**USA:**

First Sensor Inc.  
 5700 Corsa Avenue #105  
 Westlake Village  
 CA 91362 USA  
 T +1 818 706 3400  
 F +1 818 889 7053  
 sales.us@first-sensor.com

**Technical Drawing, Package: LCC6.1**

**Application hints:**

- Current should be limited by a protecting resistor or current limiting - IC inside the power supply
- For low light level applications blocking of ambient light should be used
- For high gain applications bias voltage should be temperature compensated
- Please consider basic ESD protection while handling
- Use low noise read-out - IC
- For further questions please refer to document "Instructions for handling and processing"
- Optimum gain: 50-60

**European, International Sales:**

First Sensor AG  
 Peter-Behrens-Strasse 15  
 12459 Berlin  
 Germany  
 T +49 30 6399 2399  
 F +49 30 639923-752  
 sales.opto@first-sensor.com

**USA:**

First Sensor Inc.  
 5700 Corsa Avenue #105  
 Westlake Village  
 CA 91362 USA  
 T +1 818 706 3400  
 F +1 818 889 7053  
 sales.us@first-sensor.com

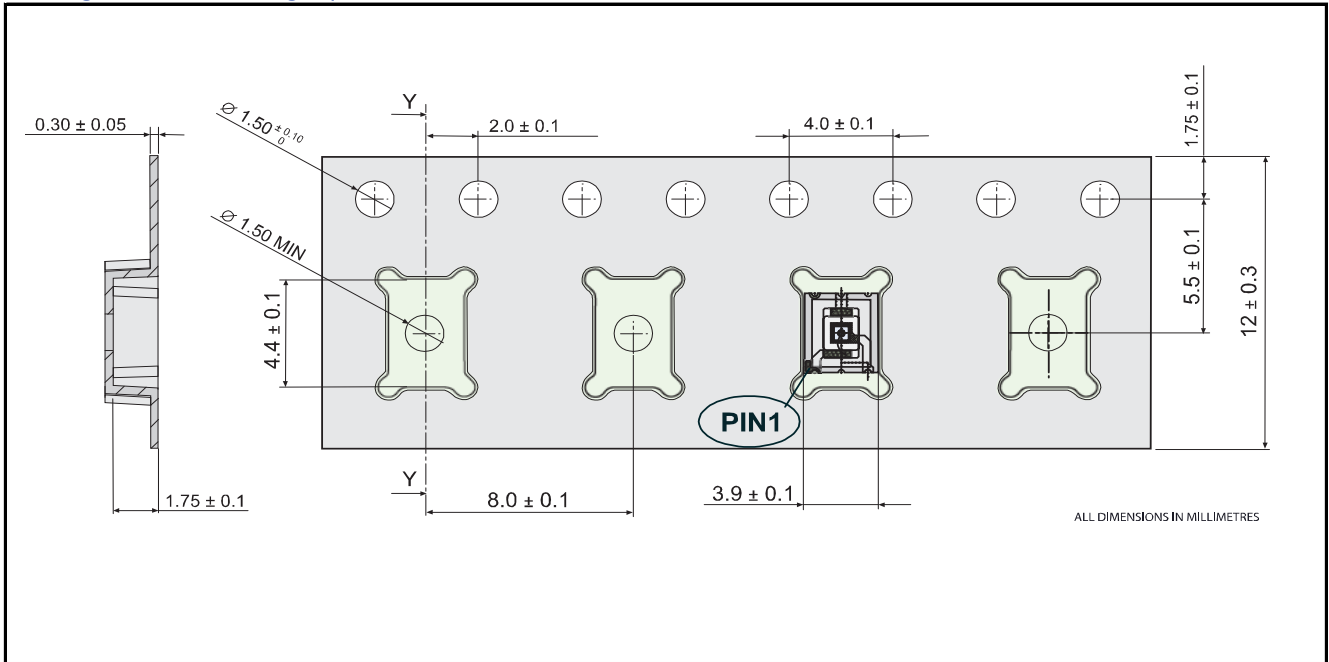
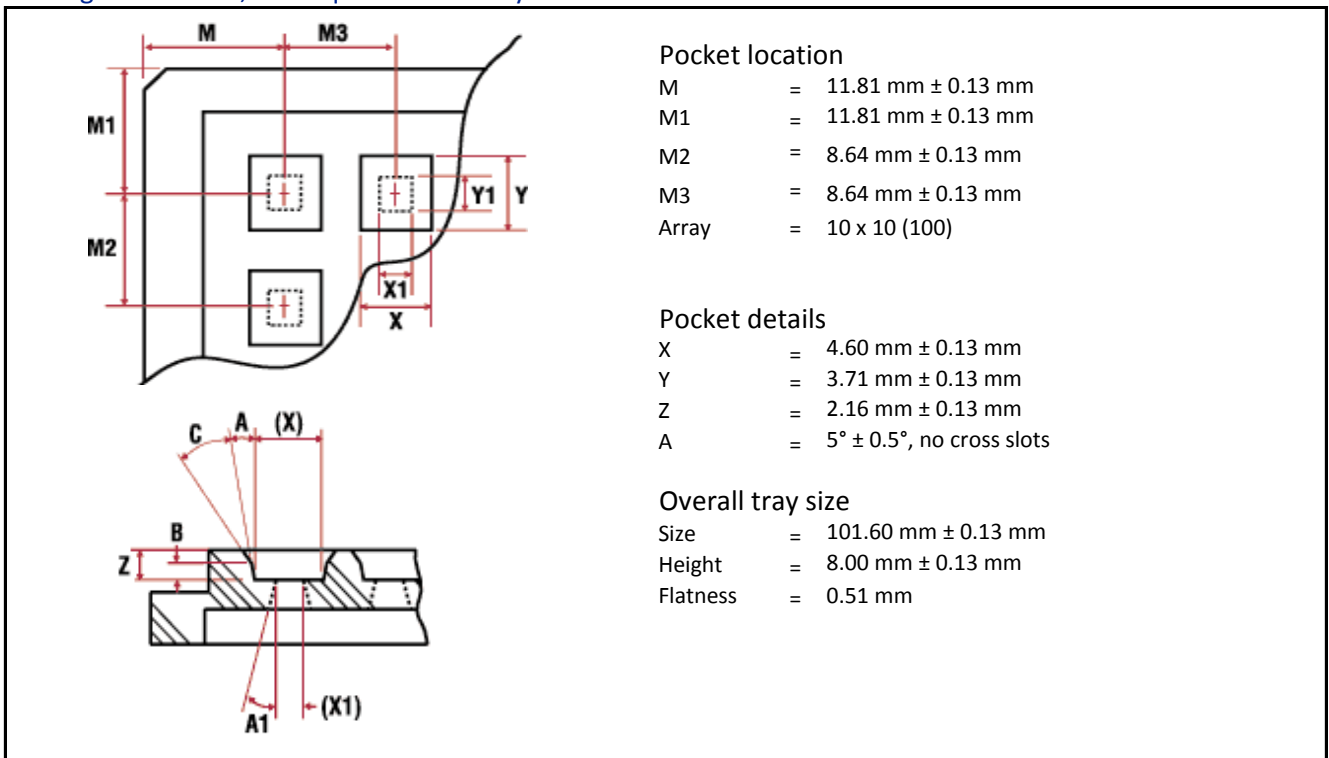
**Package dimension, large quantities on reel**

**Package dimension, small quantities in trays**

Disclaimer: Due to our strive for continuous improvement, specifications are subject to change within our PCN policy according to JESD46C.

**European, International Sales:**

First Sensor AG  
 Peter-Behrens-Strasse 15  
 12459 Berlin  
 Germany  
 T +49 30 6399 2399  
 F +49 30 639923-752  
 sales.opto@first-sensor.com

**USA:**

First Sensor Inc.  
 5700 Corsa Avenue #105  
 Westlake Village  
 CA 91362 USA  
 T +1 818 706 3400  
 F +1 818 889 7053  
 sales.us@first-sensor.com