

High Power Laser Diode

Specifications:

| parameter | Units | 793nm | | 880nm | 940nm | 1.64nm |
|---|------------|------------------|-------------|-------------|--------------|--------------|
| continuous output power(P) | W | 3 | 5 | 2 | 4 | 2.5 |
| Light-emitting area | um | 100*1 | | 150*1 | | |
| operating wavelength (λ_c) | nm | 790 \pm 3 | | 880 \pm 5 | 940 \pm 10 | 1060 \pm 5 |
| spectral width ($\Delta \lambda$) | nm | ≤ 2 | | | | |
| Working current (I_o) | A | ≤ 4.1 | ≤ 4.8 | ≤ 2.5 | ≤ 4.1 | ≤ 3.0 |
| Working Voltage(V_f) | V | ≤ 2.3 | | | | |
| Threshold Current(I_{th}) | A | ≤ 0.70 | ≤ 0.90 | ≤ 0.5 | ≤ 0.35 | ≤ 0.3 |
| slope efficiency(E_s) | W/A | > 1.0 | | | | |
| differential resistance (R_d) | Ω | ≤ 0.2 | | | | |
| photoelectric conversion efficiency | % | $> 50\%$ | | | | |
| Beam Divergence ($\theta_{\perp} \times \theta_{//}$) | $^{\circ}$ | $< 40 \times 10$ | | | | |
| life expectancy | h | $\geq 10,000$ | | | | |
| Package Type | | TO3/C-mount | | | | |

Packaging and Dimensions:

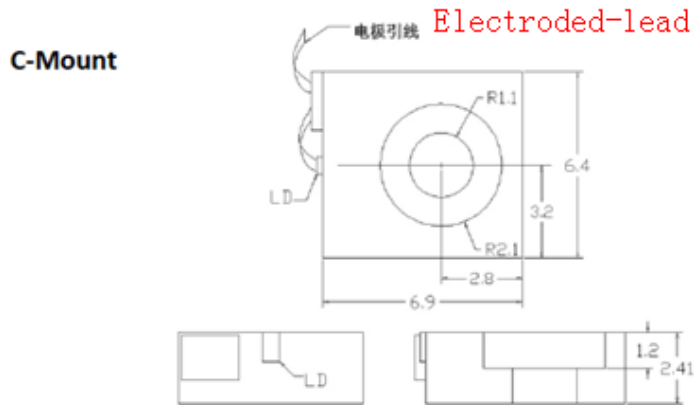

TO₃

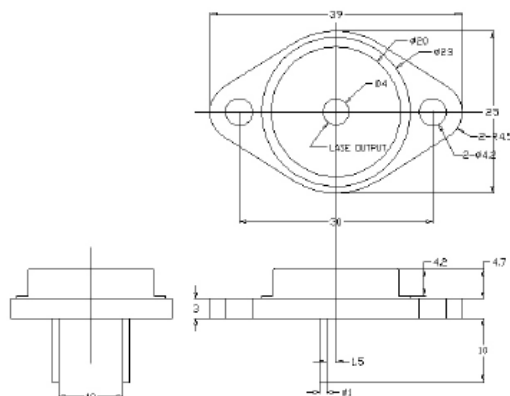

Special remind:

- (1) (1)C - Mount encapsulation , the electrode lead is negative, the tube is positive
- (2)TO3 encapsulation, Ceramic pin is negative, the tube is positive

Precautions:

(3)When the laser work, avoid eye and skin in laser irradiation

(2)anti-static measures must be taken when using and transportation and storage,During transportation and storage,the short line protection is need to connected between pins.

(3)Using the constant current power supply, avoid surge at work

(4)Should be used under the rated current rating rated current and rated power.

(5)Need to ensure good thermal when the laser work.

(6)Optimum working temperature is 25 °C

(7)Storage temperature :-20 °C ~ +60 °C